



The NetSeries impulse jet system consistently prints sharp, high-resolution images on porous surfaces in the most challenging of industrial environments. The enhanced print head design allows for an easy swap of the Net 2 and Net 4 print heads, drastically reducing downtime.



NetSeries™

The NetSeries high-resolution inkjet system is engineered to deliver simplicity, reliability, flexibility and efficiency over the life of the system while meeting GS1 barcode requirements.

SIMPLE

Creating messages using the Microsoft Windows-based graphic user interface is easier than ever. The control system quickly connects to the monitor and is fully compatible with older messages.

FLEXIBLE

The compact, industrial design fits the widest range of production line speeds and configurations.

RELIABLE

The quick disconnect printer module is rapidly brought online to ensure the highest uptime during preventative maintenance, extend the life of the system and provide the lowest cost of ownership.

EFFICIENT

Proven piezo technology ensures precise industry leading ink throw distance. This combined with the robust design allows manufacturers to operate the system in the harshest of industrial environments.

FOXJET®

TECHNICAL DATA

Print height	2 inches (Net 2) 4 inches (Net 4)
Print resolution	64 x 300 DPI (100-300 DPI user selectable range)
Print speed*	Alphanumeric: Up to 200 FPM @ 200 DPI Barcode: Up to 130 FPM @ 300 DPI Up to 150 FPM @ 200 DPI <i>*Higher line speeds achievable with reduction of DPI</i>
Throw distance	Up to 1/4" for barcodes Up to 1/2" for text (application dependent) <i>*Best barcodes at 1/8" and 300 DPI</i>
Print options	Side panel, incline panel, angled print head
Environment	Ambient operating temperature: 40°F to 104°F, operating humidity: 5-90% non-condensing
Regulatory listing	IEC62368-1
Compatible substrates	ScanTrue III is a porous ink



FEATURES & BENEFITS

- Patented quick disconnect printer modules for easy swap
- Localized wireless connectivity to controller
- Capable of connecting up to 8 print heads
- Prints messages up to 4 inches from a single print head
- Industry leading ink throw distance up to 1/2" on text
- 24-month shelf life of new, unopened cartridges and bottles
- Smart ink cartridge monitors ink levels and type
- Automatic cleaning for high-quality printing
- Durable, fully repairable printer modules
- Reinforced roller retractors protect print heads
- Maximum system control flexibility
- Industrial touchscreen controller

TECHNICAL DRAWINGS

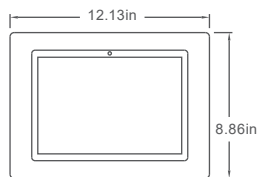

HMI

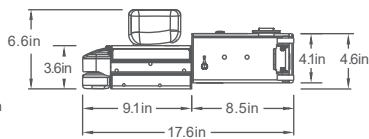

NET 2

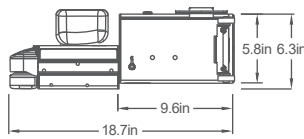

NET 4

Specifications for Net 2 & Net 4 are the same except when noted.

SYSTEM

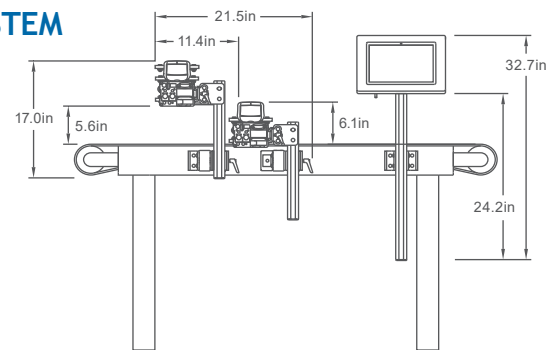

NSIJLS0124 © FoxJet 01/24